

MACCHINA BASE
BASIC MACHINE
MACHINE DE BASE
MÁQUINA BÁSICA

- ✓ *Versione RR (2 nastri abrasivi)*
R2D (Nastro abrasivo+dischi)
Version RR (2 abrasive belts)
R2D (abrasive belt+disc)
Version RR (2 bandes abrasives)
R2D (bande abrasive + Brosses tangentielles)
Versión RR (2 lija abrasivas)
R2D (lija abrasiva + cepillos de disco)
- ✓ *Larghezza utile di lavoro 1100mm*
Working width 1100mm
Largeur utile de travail 1100 mm
Ancho de trabajo 1100mm
- ✓ *Spessore di lavoro min/max 0,5-150mm*
Épaisseur de travail min /max 0,5-150mm
Working thickness min/max 0,5-150mm
Grosor del trabajo min/max 0,5-150mm
- ✓ *Dimensione nastri abrasivi (sviluppo) 1900mm*
spazzole Ø200mm
Size abrasive belts (development) 1900mm
discs Ø200mm
Dimension bandes abrasives développement 1900 mm
brosses tangentielles Ø200mm
Tamaño bandas abrasivas (desarrollo) 1900mm
cepillos de disco Ø200mm
- ✓ *Inverter avanzamento*
Feed belt inverter
Convertisseur control vitesse d'entraînement
Inverter por el control de velocidad de avance
- ✓ *Depressore interno (taratura variabile, inverter)*
Internal vacuum fan (setting variable, inverter)
Dépresseur à l'intérieur (réglage variable avec convertisseur)
Ventilador de vacío interno (variable de ajuste, inverter)



Easy M1100
RR - R2D

Layout dedicato
Dedicated layout
Configuration dédiée
Diseño dedicado



Need Help?

No problem. Just connect the electronic cable we gave you to the machine. EMC technician will do the rest of the job.

"Look no further for a better finishing!
We have what you're looking for.
Make your choice".



Headquarter Via Brodolini, 23
Production Via Altobelli, 8/A
 40026 IMOLA (Bo) Italy
 Tel. +39 0542 688034
 E-mail: info@emc-italia.it



www.emc-italia.it



www.emc-italia.it



Easy M1100

RR - R2D



EMC Italia srl



EMC Italia srl

EMC si riserva il diritto di modificare le specifiche tecniche - EMC se réserve le droit de modifier les spécifications techniques - EMC se reserva el derecho de cambiar las especificaciones técnicas - Printed by Nuova Grafica & Tecnologia - Imola

RR

R2D

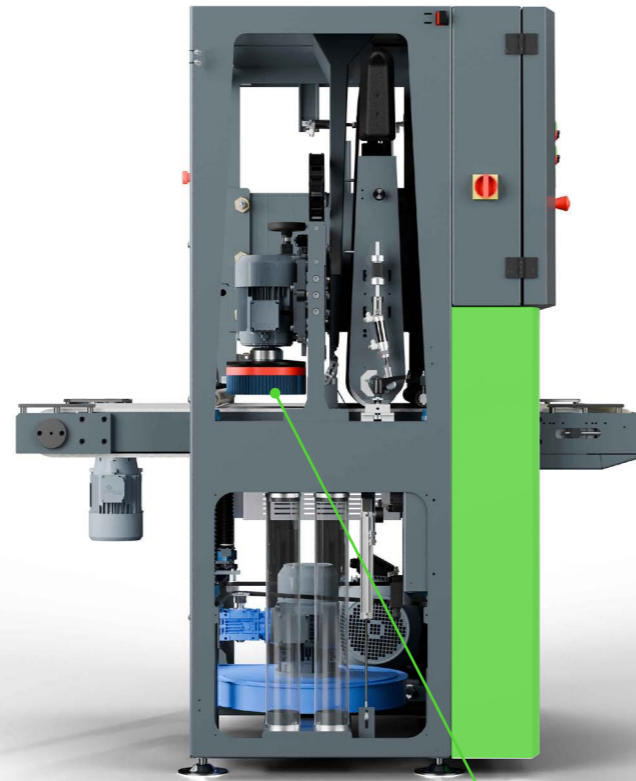
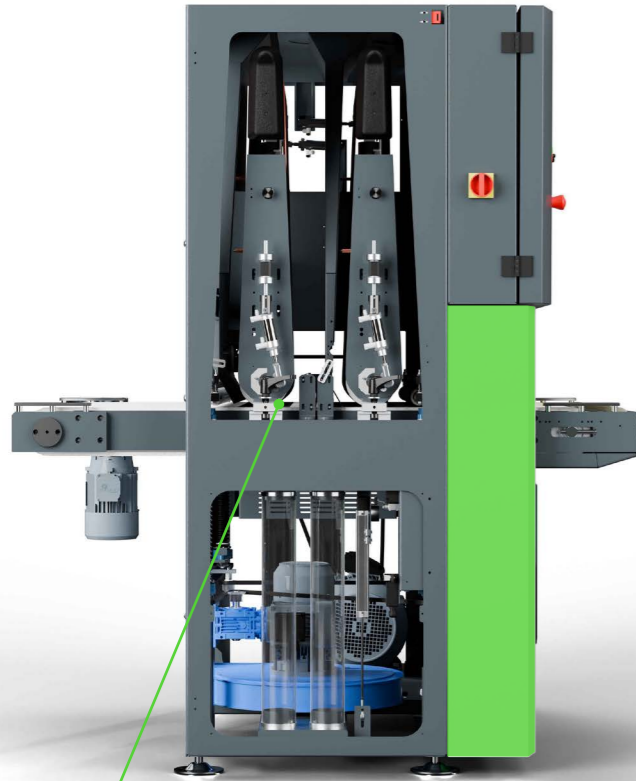

Sistema on-off manuale
Manual on-off system
Système on off manuel
Manual del sistema de
encendido y apagado

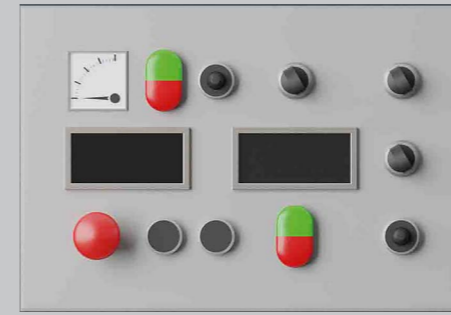
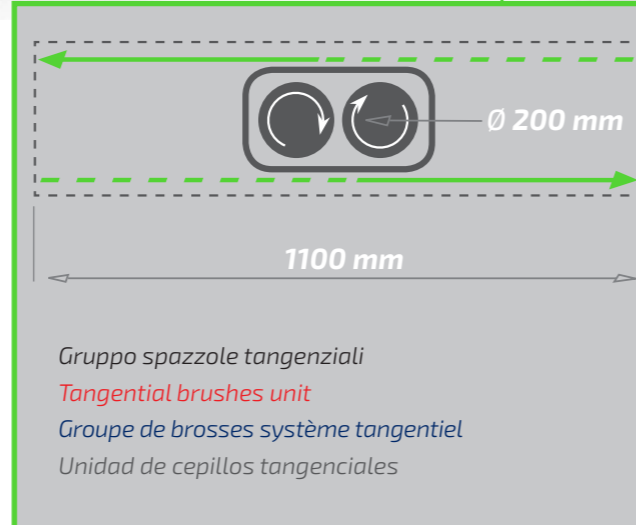

Pannello di controllo Analogico
Analogic Control Panel
Panneau de control analogique
Panel de control analógico

Rulliere di estensione
Rollers table extension
Rouleaux de prolongement
Extensión de mesa, rodillos

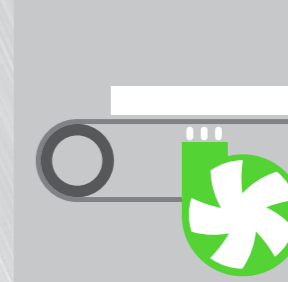

Depressore interno
(taratura variabile,
invertir)
Internal vacuum fan
(setting variable, invertir)
Dépresseur à l'intérieur
(réglage variable avec
convertisseur)
Ventilador de vacío
interno (variable de
ajuste, invertir)

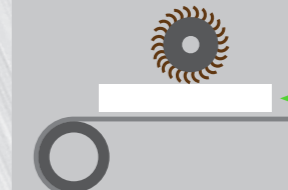

Spazzola pulizia pezzi
Brush for panels
cleaning
Brosse de nettoyage
pièces
Cepillo para limpieza
de paneles

METALWORKING PROCESSES MADE BY OUR MACHINES

Acciai
Steel
Aciers
Acero

Acciai inossidabili
Stainless steel
Aciers inoxydables
Acero inoxidable

Alluminio
Aluminium
Aluminium
Aluminio

Materiali Avanzati
Advanced materials
Matériaux avancés
Materiales avanzados

SBAVATURA
DEBURRING
ÉBAVURAGE
DESBARBADO



RAGGIATURA SPIGOLI
EDGE ROUNDING
ARRONDI DES BORDS
REDONDEO DE BORDES



SATINATURA E RETTIFICA
FINISHING & GRINDING
BROSSAGE DE FINITION
ACABADO



Complete and easy to use

LARGHEZZA DI LAVORO WORKING WIDTH LARGEUR DE TRAVAIL ANCHO DE TRABAJO

1100 mm

UNITÀ DISPONIBILI
AVAILABLE UNITS
UNITÉ DISPONIBLE
UNIDADES DISPONIBLES

